

PERENCANAAN TEKNOLOGI & SISTEM BANGUNAN (PTSB) 03

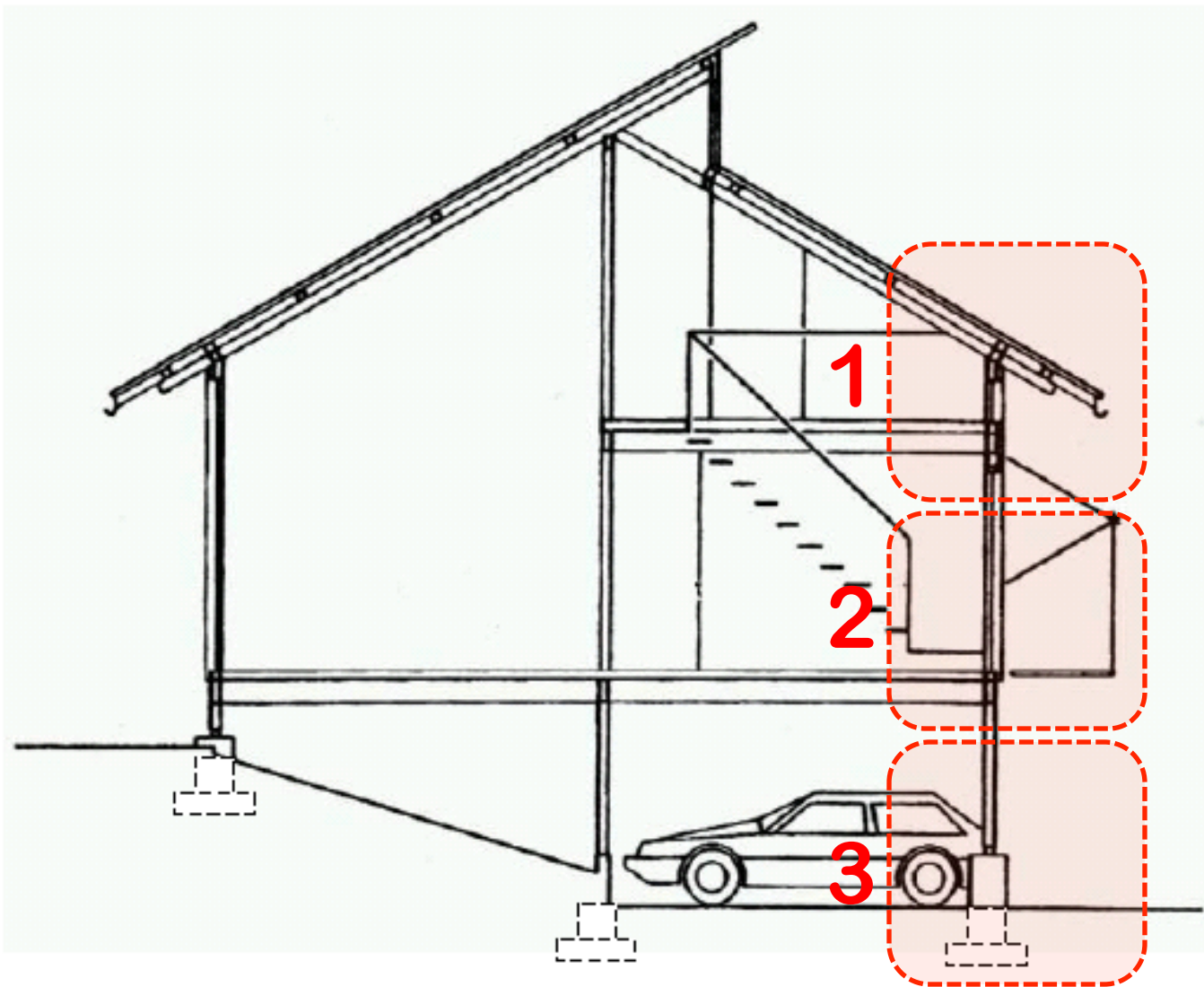

<i>Walls</i>	lb/ft ²	<i>Masonry</i>	lb/ft ³
Clay brick		Cast-stone masonry	144
High-absorption, per 4-in wythe	34	Concrete, stone aggregate, reinforced	150
Medium-absorption, per 4-in wythe	39	Ashlar:	
Low-absorption, per 4-in wythe	46	Granite	165
Sand-lime brick, per 4-in wythe	38	Limestone, crystalline	165
Concrete brick		Limestone, oölitic	135
4-in, with heavy aggregate	46	Marble	173
4-in, with light aggregate	33	Sandstone	144
Concrete block, hollow		<i>Roof and Wall Coverings</i>	lb/ft ²
8-in, with heavy aggregate	55	Clay tile shingles	9 to 14
8-in, with light aggregate	35	Asphalt shingles	2
12-in, with heavy aggregate	85	Composition:	
12-in, with light aggregate	55	3-ply ready roofing	1
Clay tile, loadbearing		4-ply felt and gravel	5.5
4-in	24	5-ply felt and gravel	6
8-in	42	Copper or tin	1
12-in	58	Corrugated steel	2
Clay tile, nonloadbearing		Sheathing (gypsum), ½-in	2
2-in	11	Sheathing (wood), per in thickness	3
4-in	18	Slate, ¼-in	10
8-in	34	Wood shingles	2
Furring tile		<i>Waterproofing</i>	lb/ft ²
1½-in	8	Five-ply membrane	5
2-in	10	<i>Ceilings</i>	lb/ft ²
Glass block, 4-in	18	Plaster (on tile or concrete)	5
Gypsum block, hollow		Suspended metal lath and gypsum plaster	10
2-in	9.5	Suspended metal lath and cement plaster	15
4-in	12.5	Suspended steel channel supports	2
6-in	18.5	Gypsumboard per ¼-in thickness	1.1

<i>Floor Finishes</i>	lb/ft ²
Asphalt block, 2-in	24
Cement, 1-in	12
Ceramic or quarry tile, 1-in	12
Hardwood flooring, 7/8-in	4
Plywood subflooring, 1/2-in	1.5
Resilient flooring, such as asphalt tile and linoleum	2
Slate, 1-in	15
Softwood subflooring, per in of thickness	3
Terrazzo, 1-in	13
Wood block, 3-in	4

Wood joists, double wood floor, joist size	lb/ft ²	
	12-in spacing	16-in spacing
2 × 6	6	5
2 × 8	6	6
2 × 10	7	6
2 × 12	8	7
3 × 6	7	6
3 × 8	8	7
3 × 10	9	8
3 × 12	11	9
3 × 14	12	10

<i>Concrete Slabs</i>	lb/ft ²
Stone aggregate, reinforced, per in of thickness	12.5
Slag, reinforced, per in of thickness	11.5
Lightweight aggregate, reinforced, per in of thickness	6 to 10

<i>Floor Fill</i>	lb/ft ²
Cinders, no cement, per in of thickness	5
Cinders, with cement, per in of thickness	9
Sand, per in of thickness	8
<i>Partitions</i>	lb/ft ²
Plaster on masonry	
Gypsum, with sand, per in of thickness	8.5
Gypsum, with lightweight aggregate, per in	4
Cement, with sand, per in of thickness	10
Cement, with lightweight aggregate, per in	5
Plaster, 2-in solid	20
Metal studs	
Plastered two sides	18
Gypsumboard each side	6
Wood studs, 2 × 4-in	
Unplastered	3
Plastered one side	11
Plastered two sides	19
Gypsumboard each side	7
<i>Glass</i>	lb/ft ²
Single-strength	1.2
Double-strength	1.6
Plate, 1/8-in	1.6
<i>Insulation</i>	lb/ft ²
Cork, per in of thickness	1.0
Foamed glass, per in of thickness	0.8
Glass-fiber bats, per in of thickness	0.06
Polystyrene, per in of thickness	0.2
Urethane	0.17
Vermiculite, loose fill, per in of thickness	0.5

1 ft = 0,3048 m
1 in = 25,40 mm

1 lb/ft² = 16,019 kg/m³

lb = pounds

$$\sigma = \frac{F \text{ (k N)}}{A \text{ (m}^2\text{)}}$$

$$A = \frac{F \text{ (k N)}}{\sigma \text{ (k N/ m}^2\text{)}}$$

The 2:1 method

assumes that the stress dissipates with depth in the form of a trapezoid that has 2:1 (vertical: horizontal) inclined sides.

The purpose of this method is to approximate the actual ‘‘pressure bulb’’ stress increase beneath a footing.

$$\sigma_z = \Delta\sigma_v = \frac{P}{B + z}$$

If the footing is a rectangular spread footing having a length L and a width B , then the stress applied by the rectangular footing (σ_0) would be $\sigma_0 = P / (BL)$ where P entire load of the rectangular spread footing.

$$\sigma_z = \Delta\sigma_v = \frac{P}{(B+z)(L+z)}$$

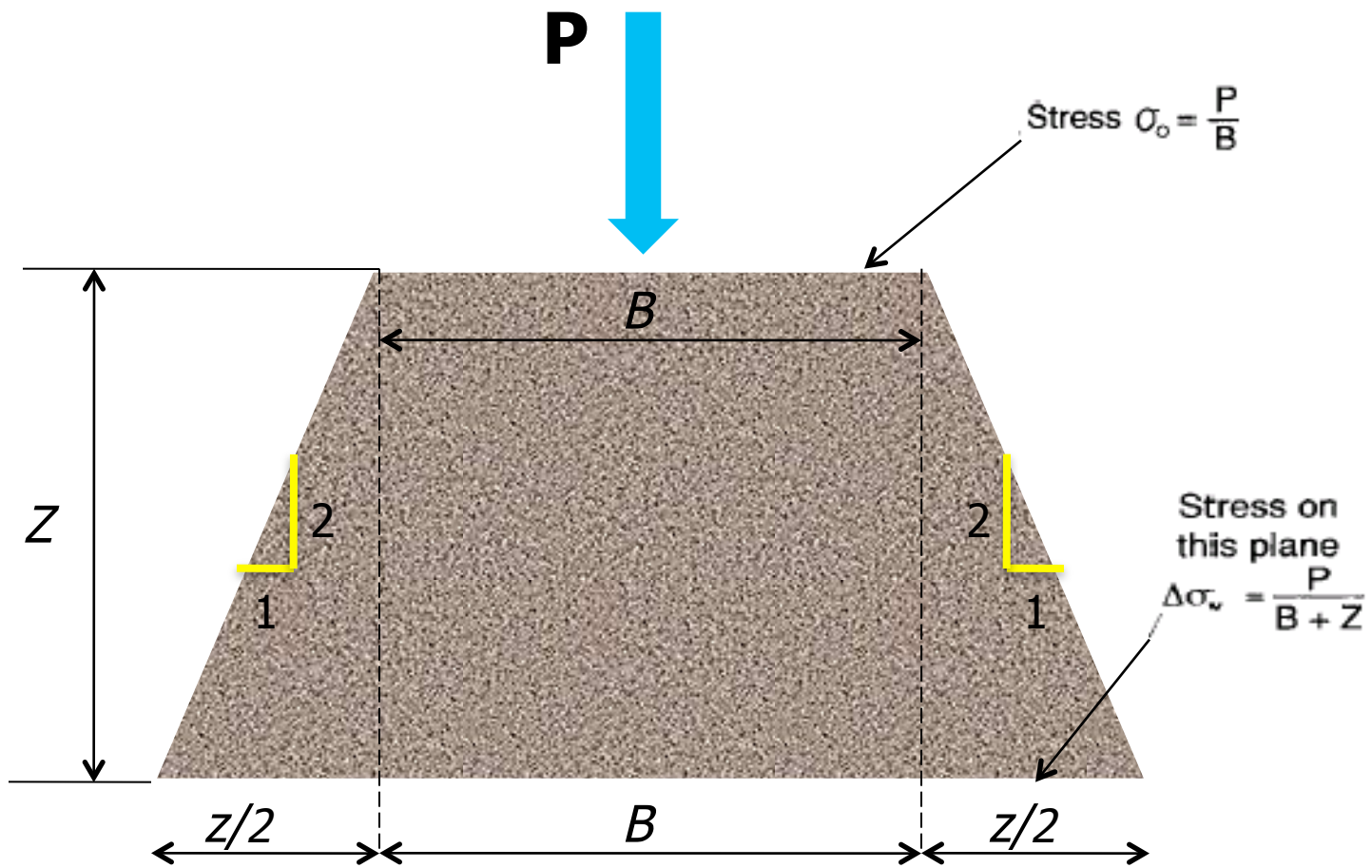

If there is known $P = 200 \text{ kN/m}$, the wall thickness = 0.49 m ,
 $\sigma = 240 \text{ kN/m}^2$, rectangular foundation length (l) = 1.00 m

using concrete B 15 determine:

1. the width of foundation (b)
2. the foundation depth (z)

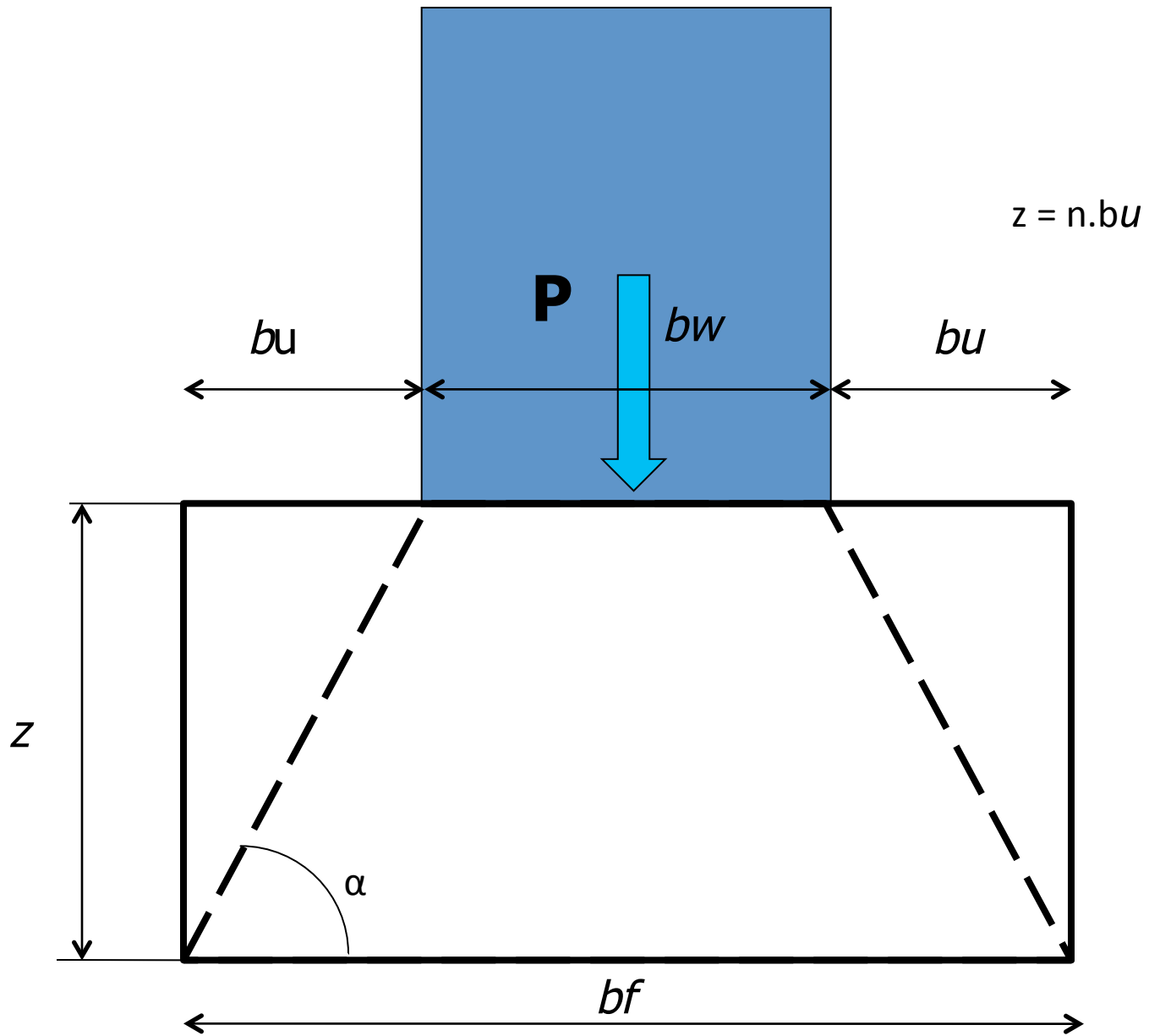

n- value for vertical stress distribution					
Permitted vertical stress increase (σ) in kN/m ²	100	200	300	400	500
B 5 (5,0 N/mm ²)	1.6	2.0	2.0	not permitted	
B 10 (10,0 N/mm ²)	1.1	1.6	2.0	2.0	2.0
B 15 (15,0 N/mm ²)	1.0	1.3	1.6	1.8	2.0
B 25 (25,0 N/mm ²)	1.0	1.0	1.2	1.4	1.6
B 35 (35,0 N/mm ²)	1.0	1.0	1.0	1.2	1.3

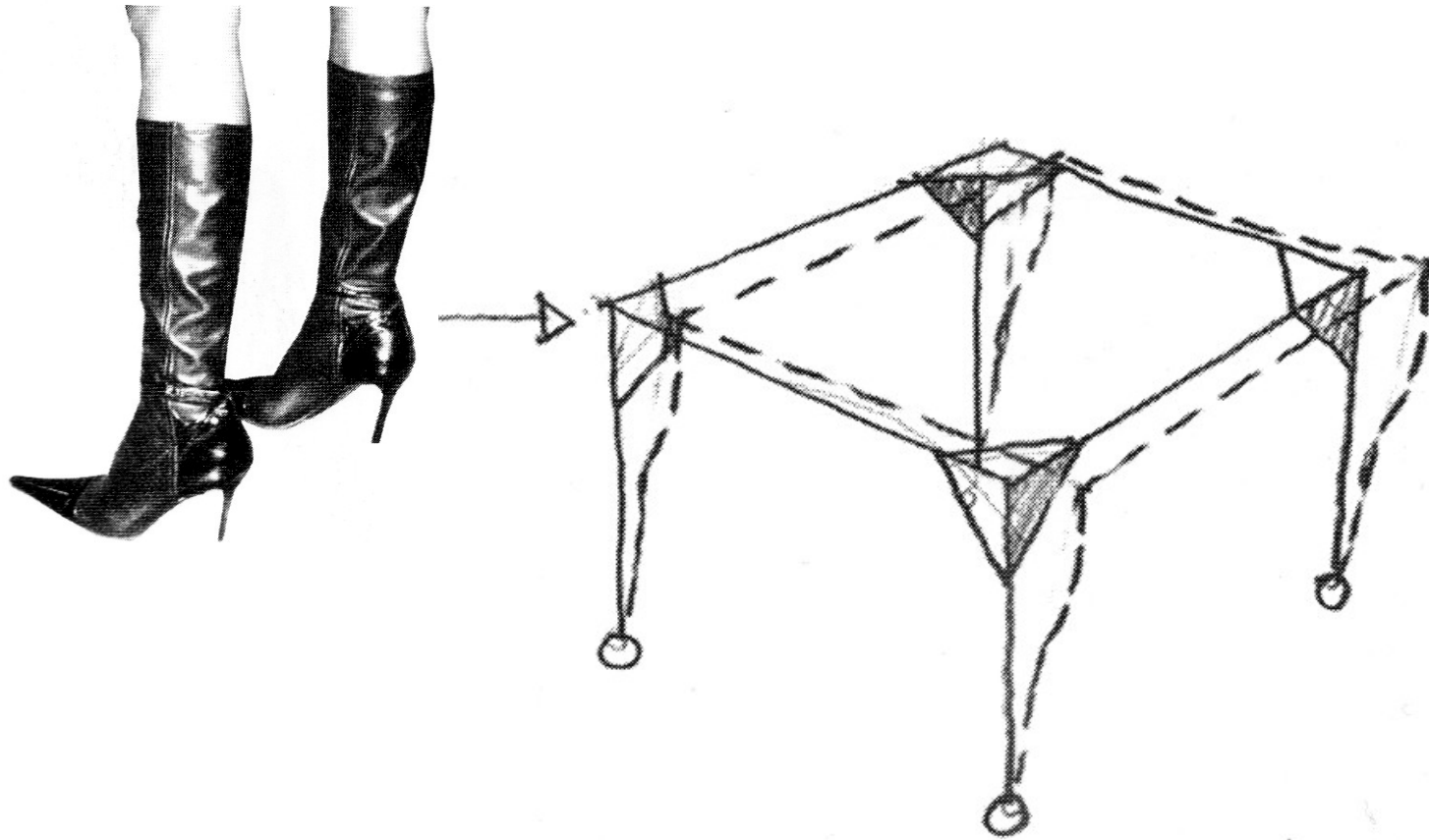

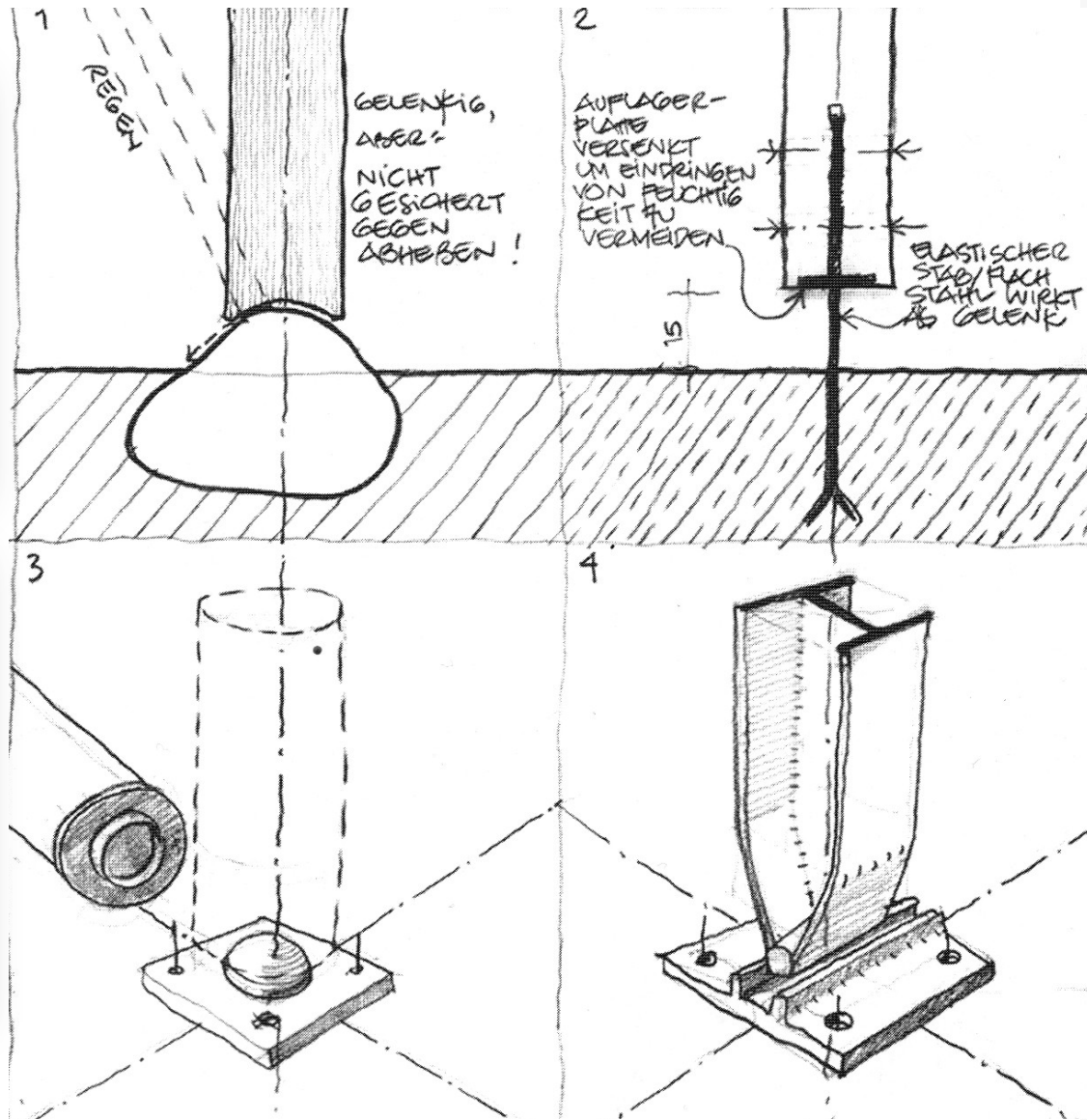
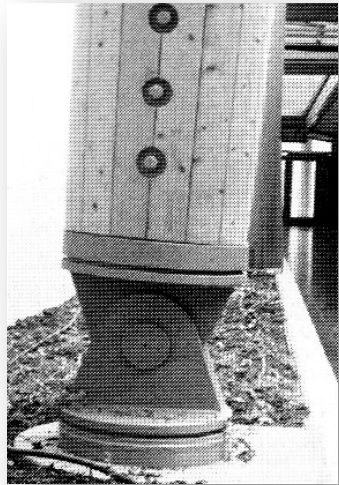
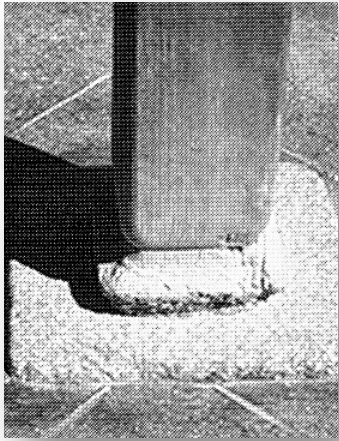

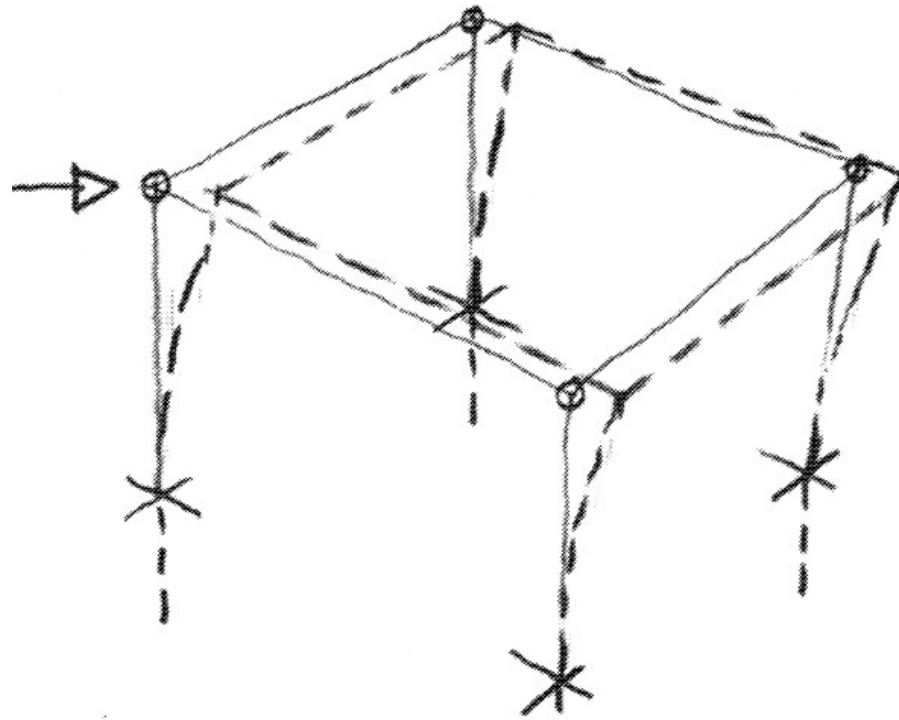

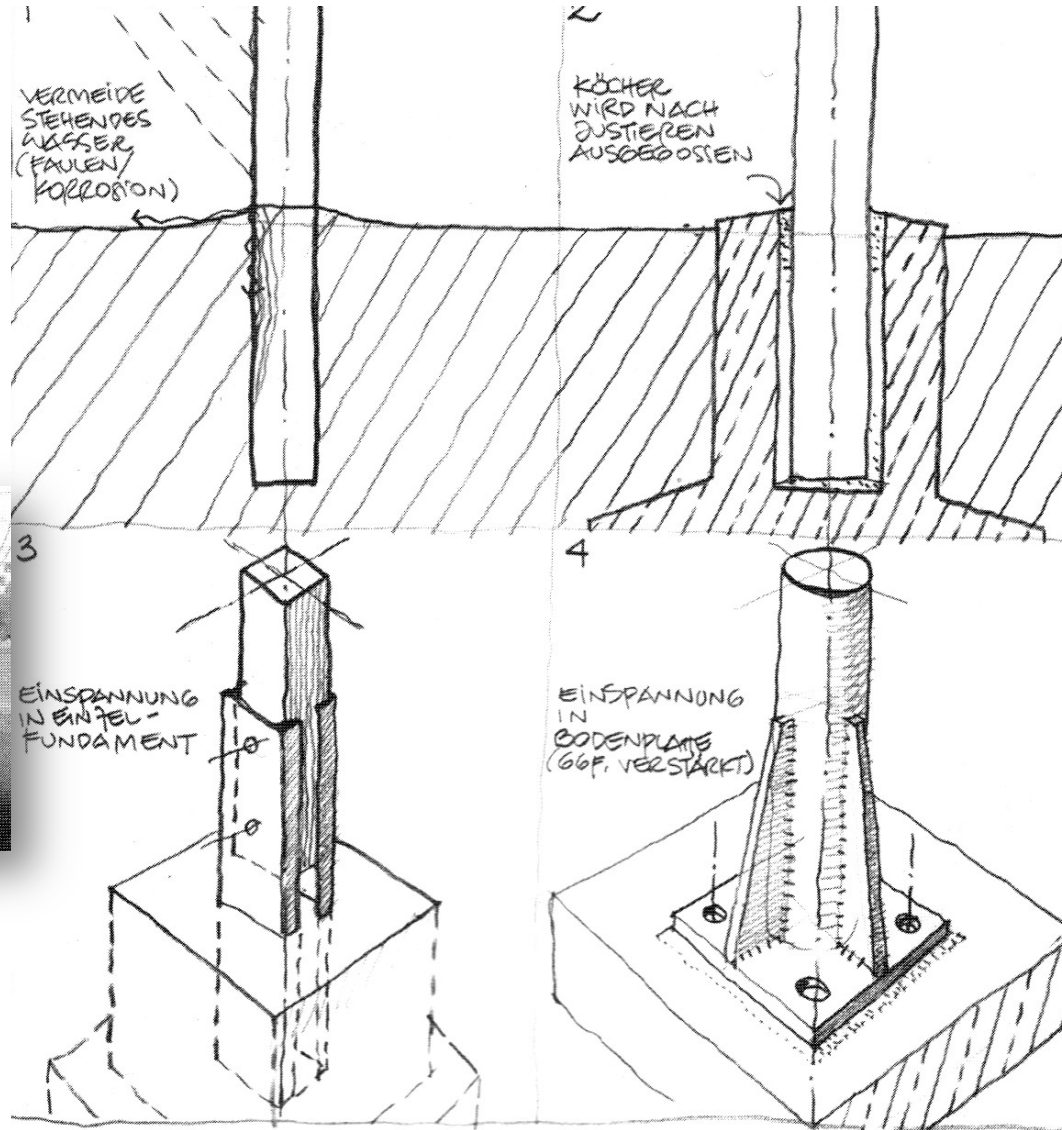

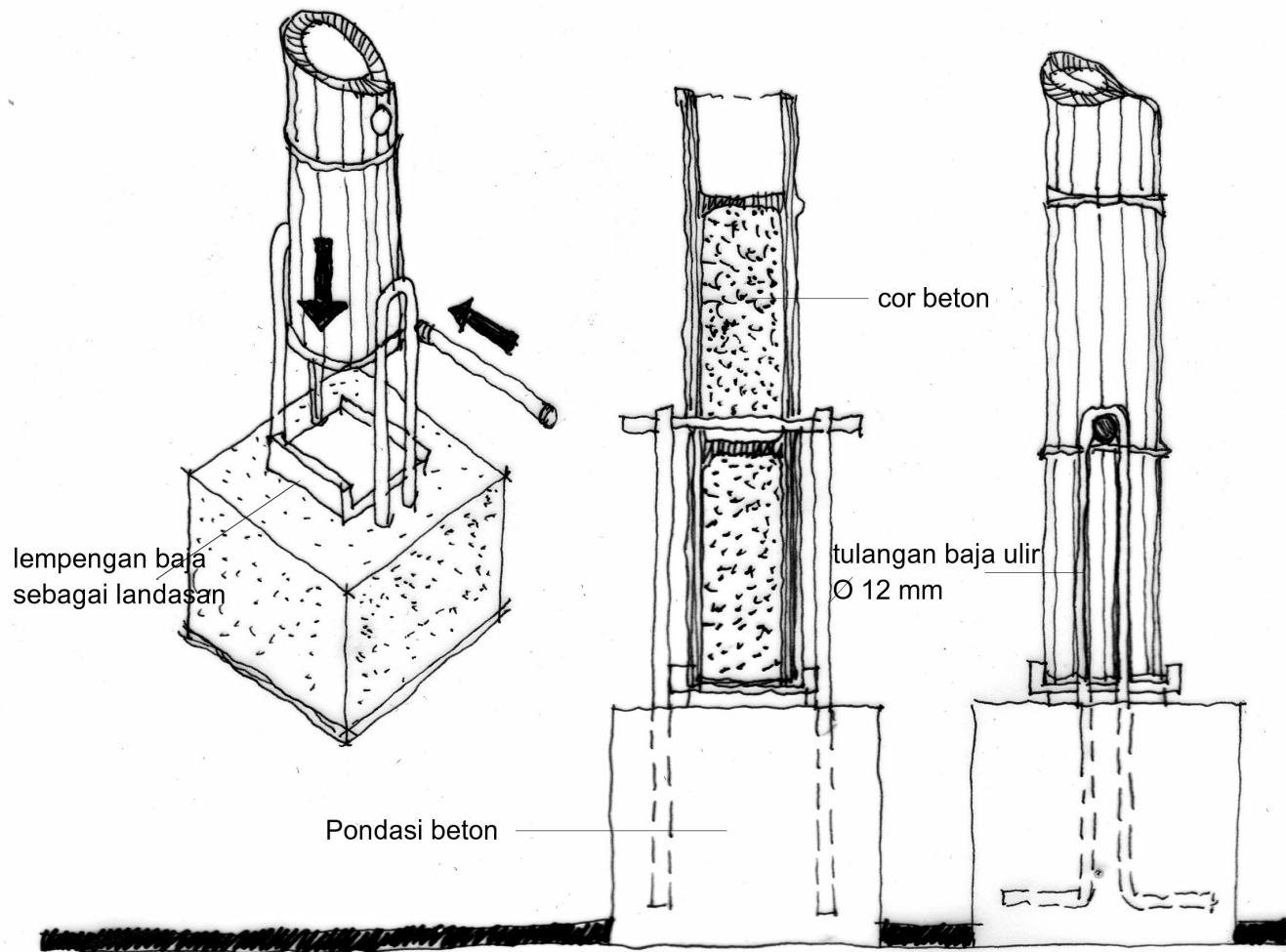

Concrete → **Steel** column

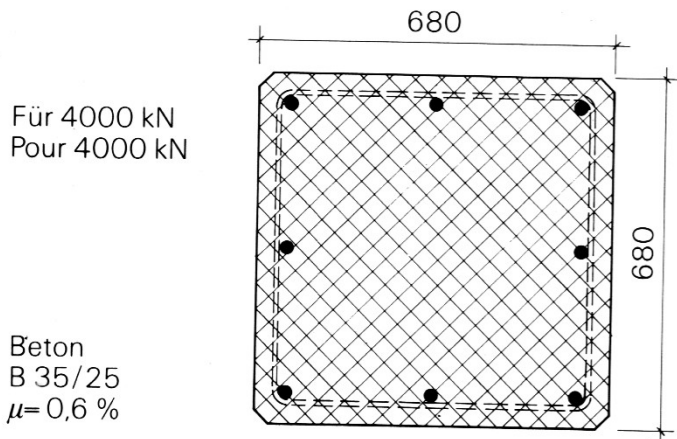

Für 4000 kN:
Stahlquerschnitte Fe 510 (F90)

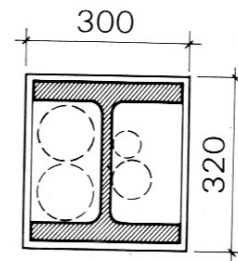

Pour 4000 kN:
Sections d'acier Fe 510 (F90)

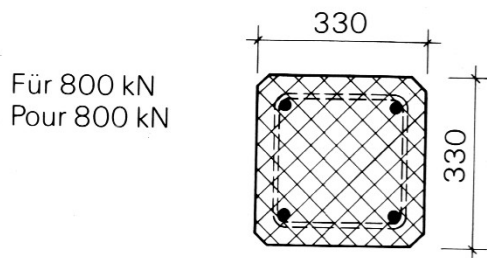
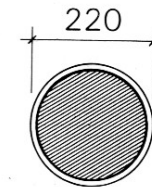
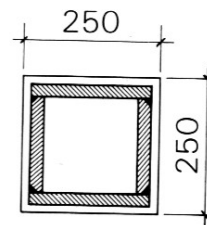

Für 800 kN:
Stahlquerschnitte Fe 510 (F90)

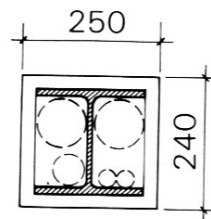

Pour 800 kN
Sections d'acier Fe 510 (F90)

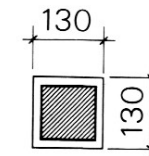
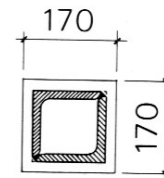

Concrete → **Steel** column

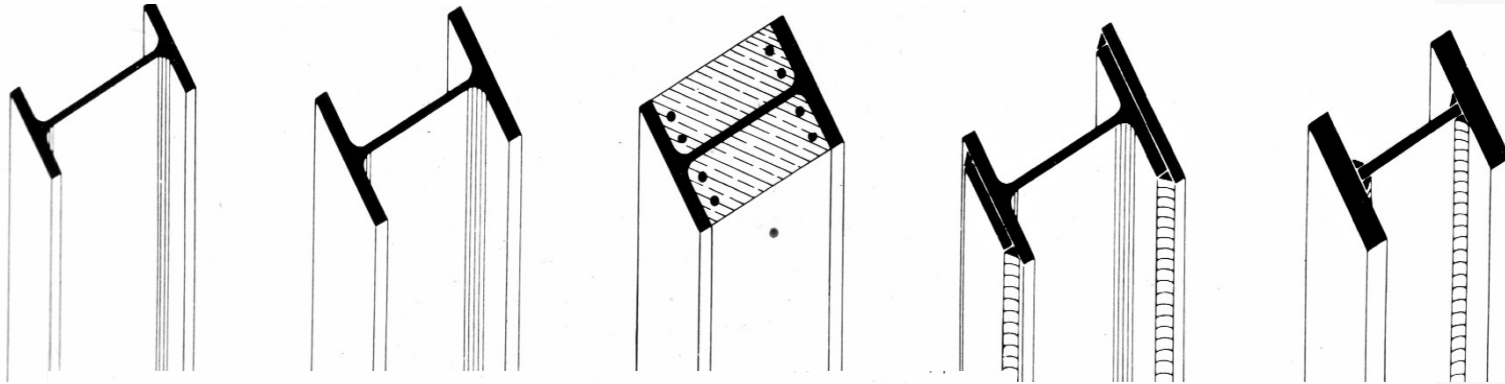

- Häufigste und wirtschaftlichste Stützenform
- Besonders gut geeignet für Anschlüsse von Trägern in beiden Richtungen
- Alle Teile des Profils für Schraubenverbindungen zugänglich
- Als Verbundquerschnitt («kammerausbetoniert») mit erhöhter Tragfähigkeit und Feuerwiderstand F60 oder F90

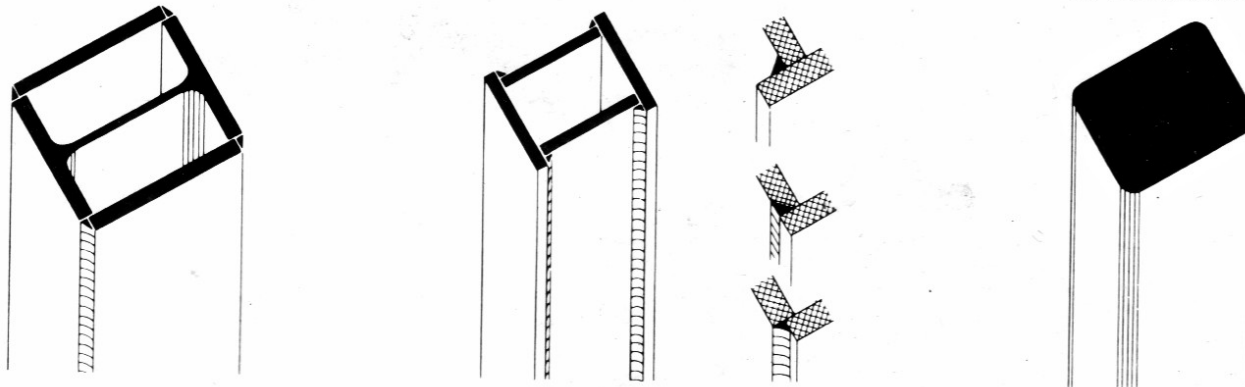

- Geeignet für Stützen mit hohen Lasten, Biegung in beiden Richtungen, grossen Knicklängen bei kleinem Querschnitt
- Wegen der glatten Aussenfläche als unverkleidete Stütze beliebt

Concrete → **Steel** column

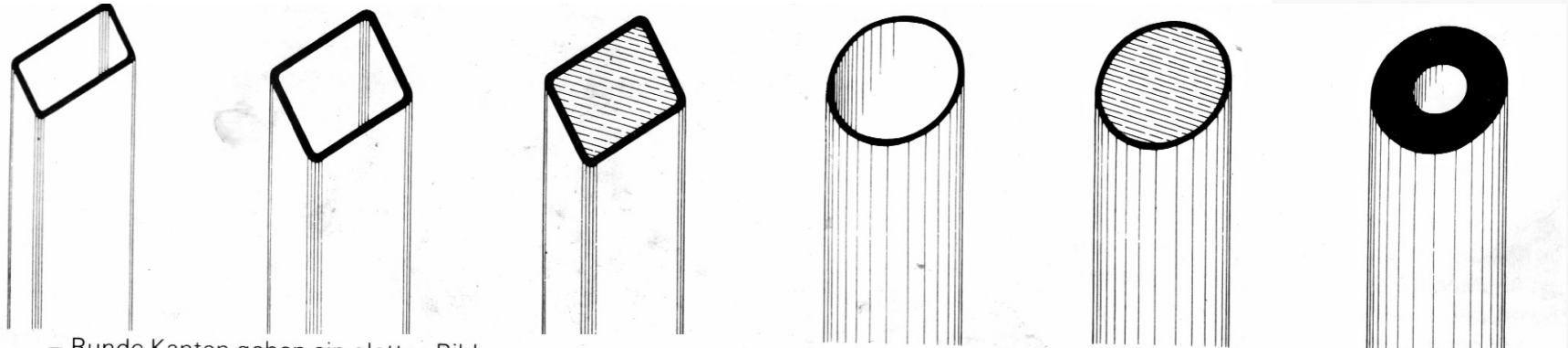

- Runde Kanten geben ein glattes Bild
- Die Einleitung der Kräfte bedarf besonderer Massnahmen
- Profile gleicher Aussenabmessung sind durch die Wanddicke abstufbar
- Ausbetonieren erhöht Tragfähigkeit und Feuerwiderstand

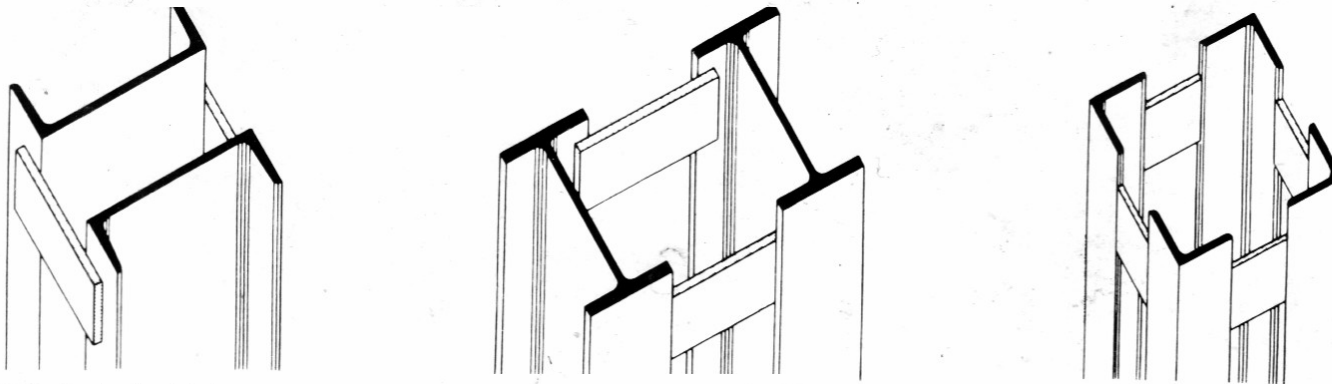

- Häufig im Industriebau
- Geeignet, wenn Unterzug zwischen den Stützhälften liegen soll oder in der Stütze die Installationen zugänglich geführt werden sollen
- Grösserer Aussenquerschnitt als Stützen unter a, b und c
- Bindebleche für Knicksteifigkeit notwendig

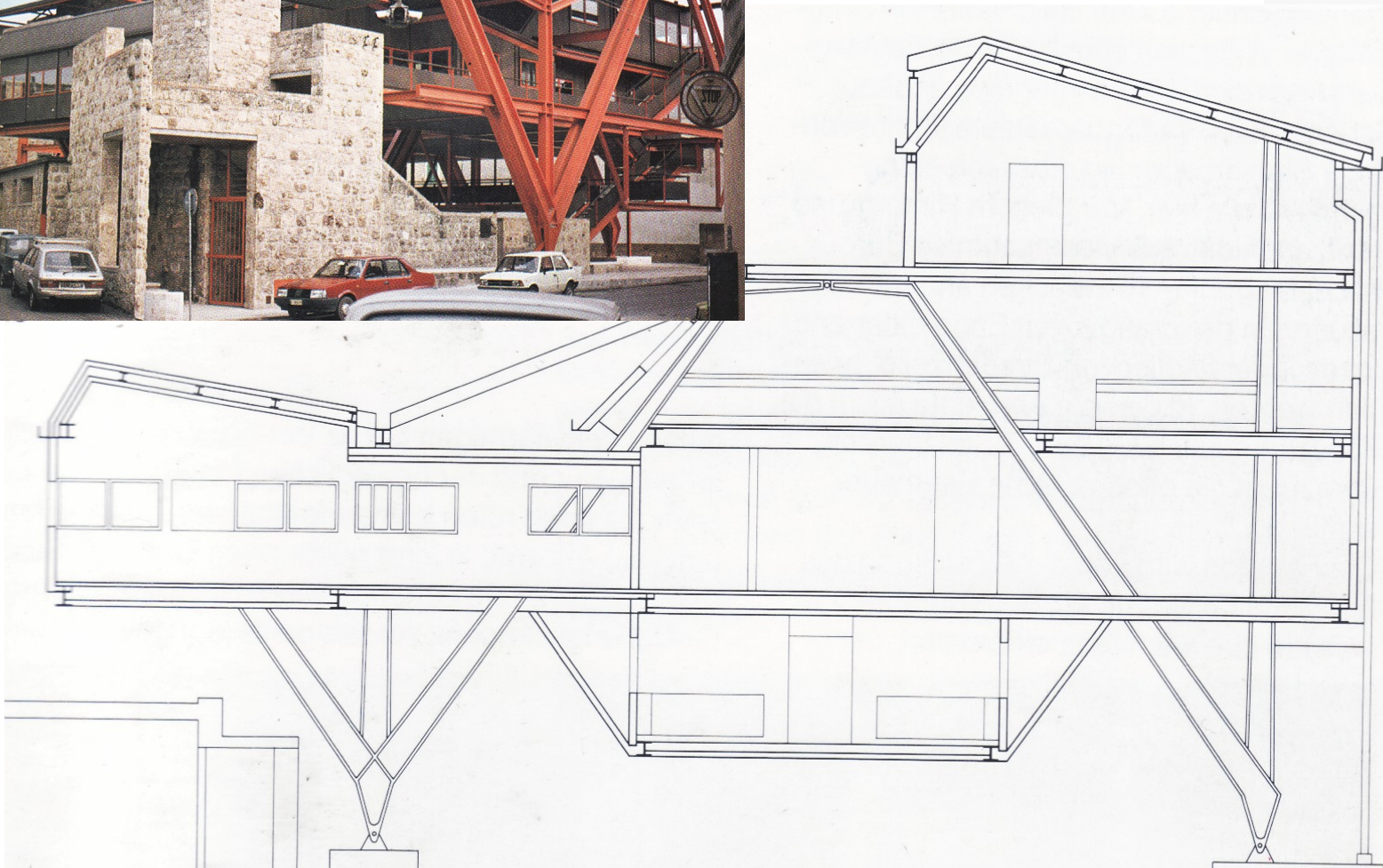

Stützenfuß Maßstab 1:100

- 1 Travertin Stützenfuß 1600/1600/340 mm
- 2 Stahlplatte am Stützenfuß 800/700/70 mm
- 3 Portalrahmen
- 4 2 LJ-Profile im Abstand von 300 mm, geschweißt, Abmessung am Fußpunkt 634 × 220 mm am Knickpunkt 330 × 220 mm am höchsten Punkt 220 × 220 mm
- 5 obere Verbindung der Portalrahmenstützen

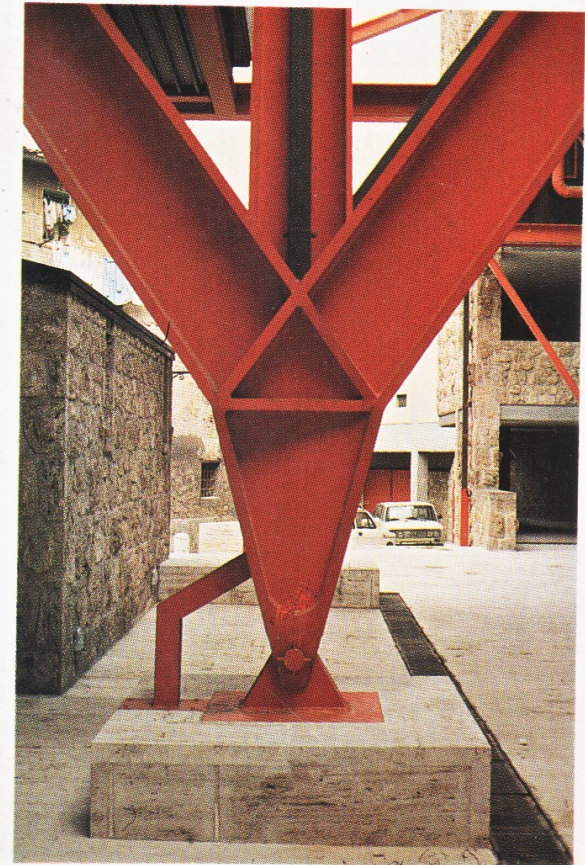
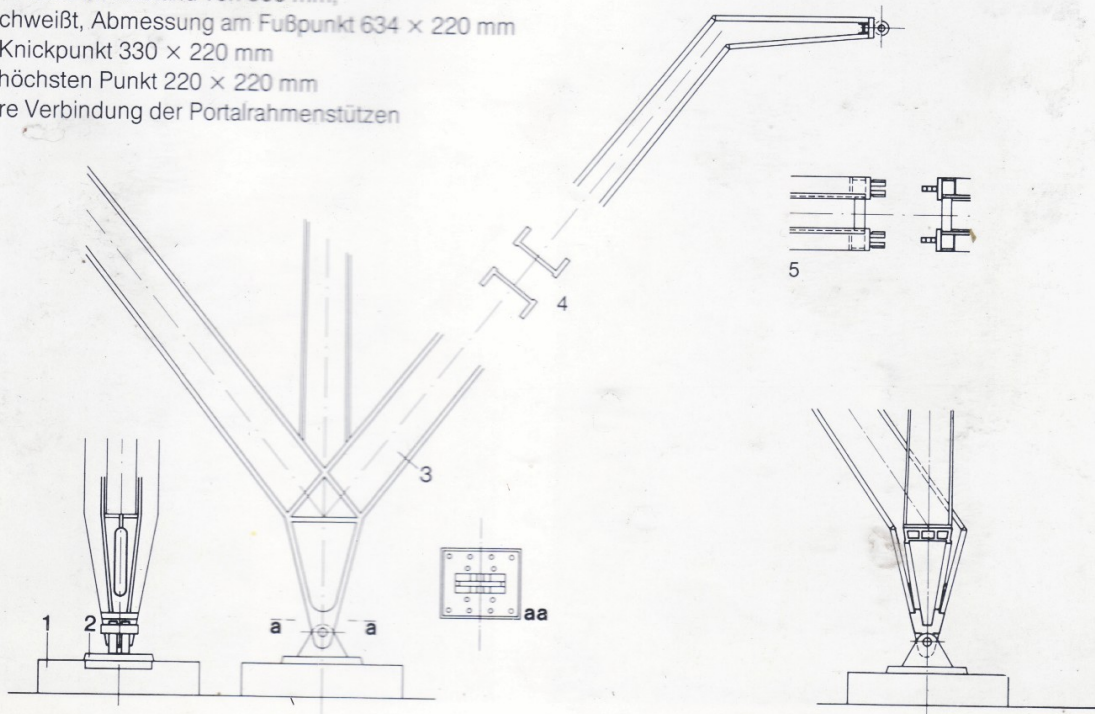

Rumah tinggal keluarga Ir. Daryanto

Jalan Sindurito Selatan VI/16, Durenkemping Barat 50148 70/54 m
 Rencana: 1 Dri: Heinz Fries, Anick SA, D. Ramadhani Baet 1/2

Potongan A-A 1:20, Terali jendela 1:20
 No. 1.00
 1 meter

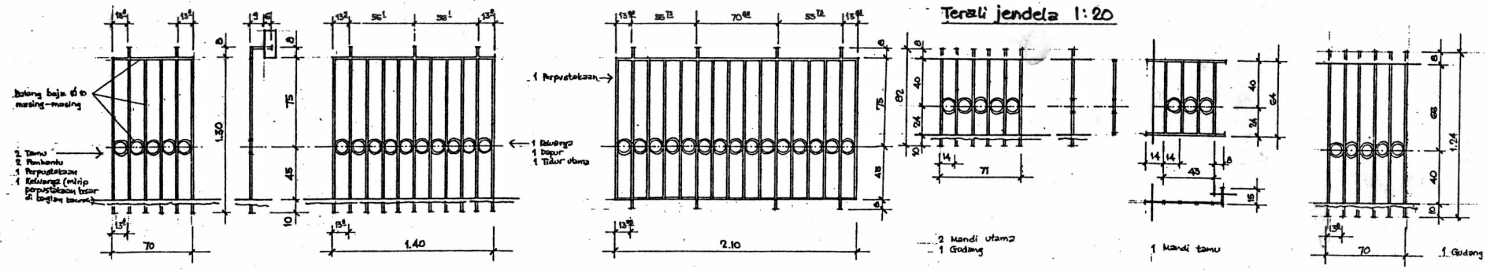
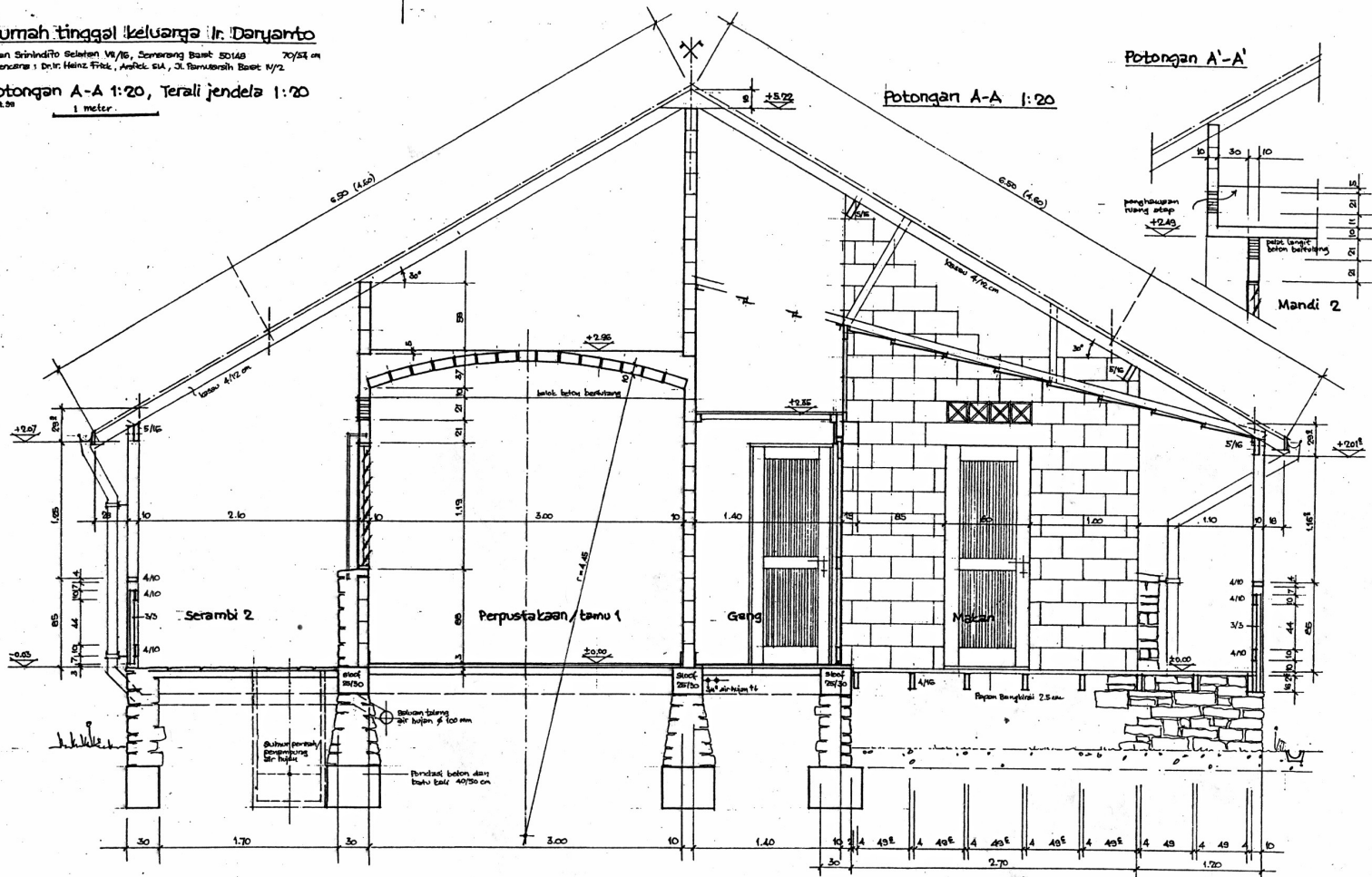

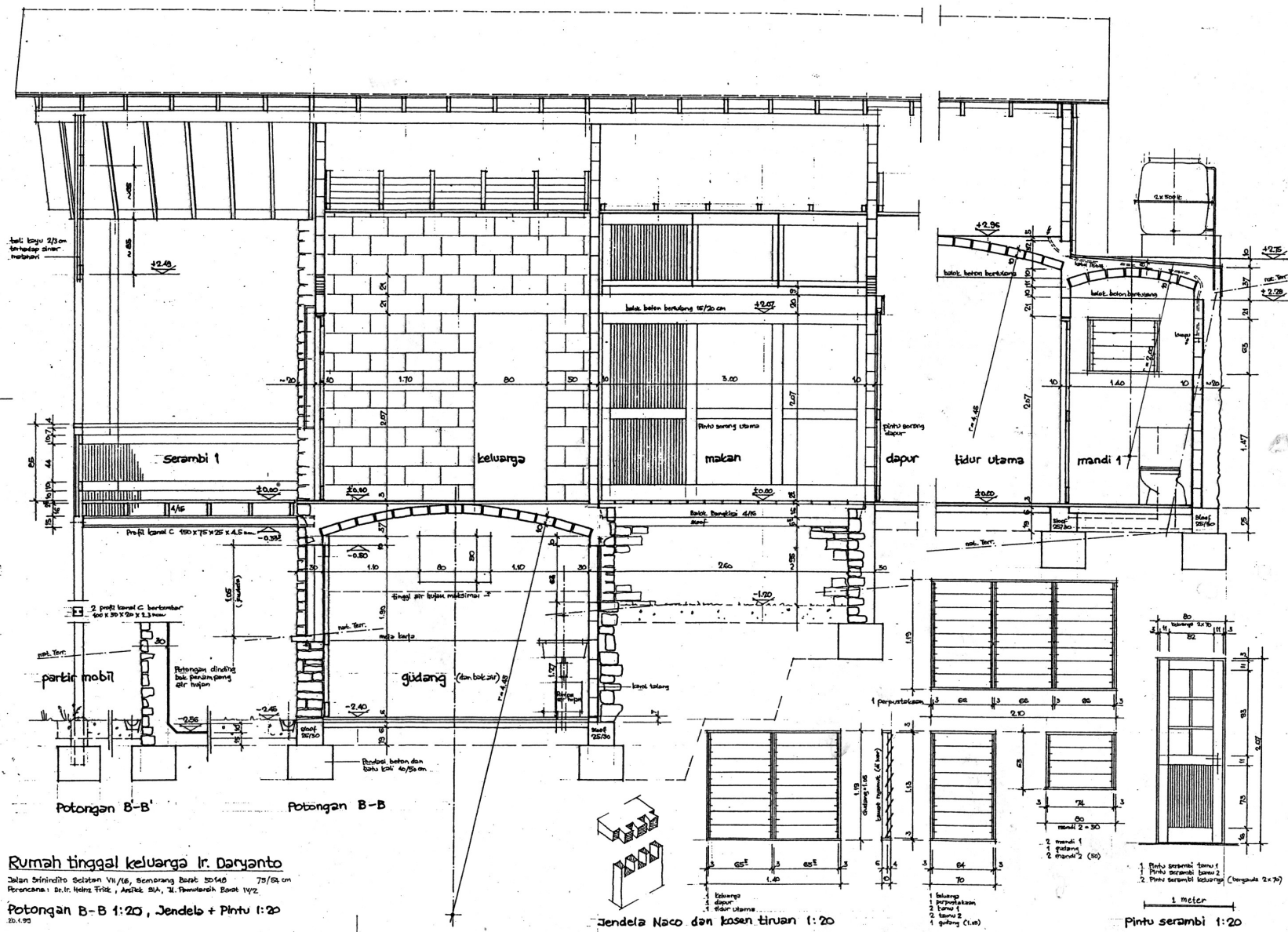

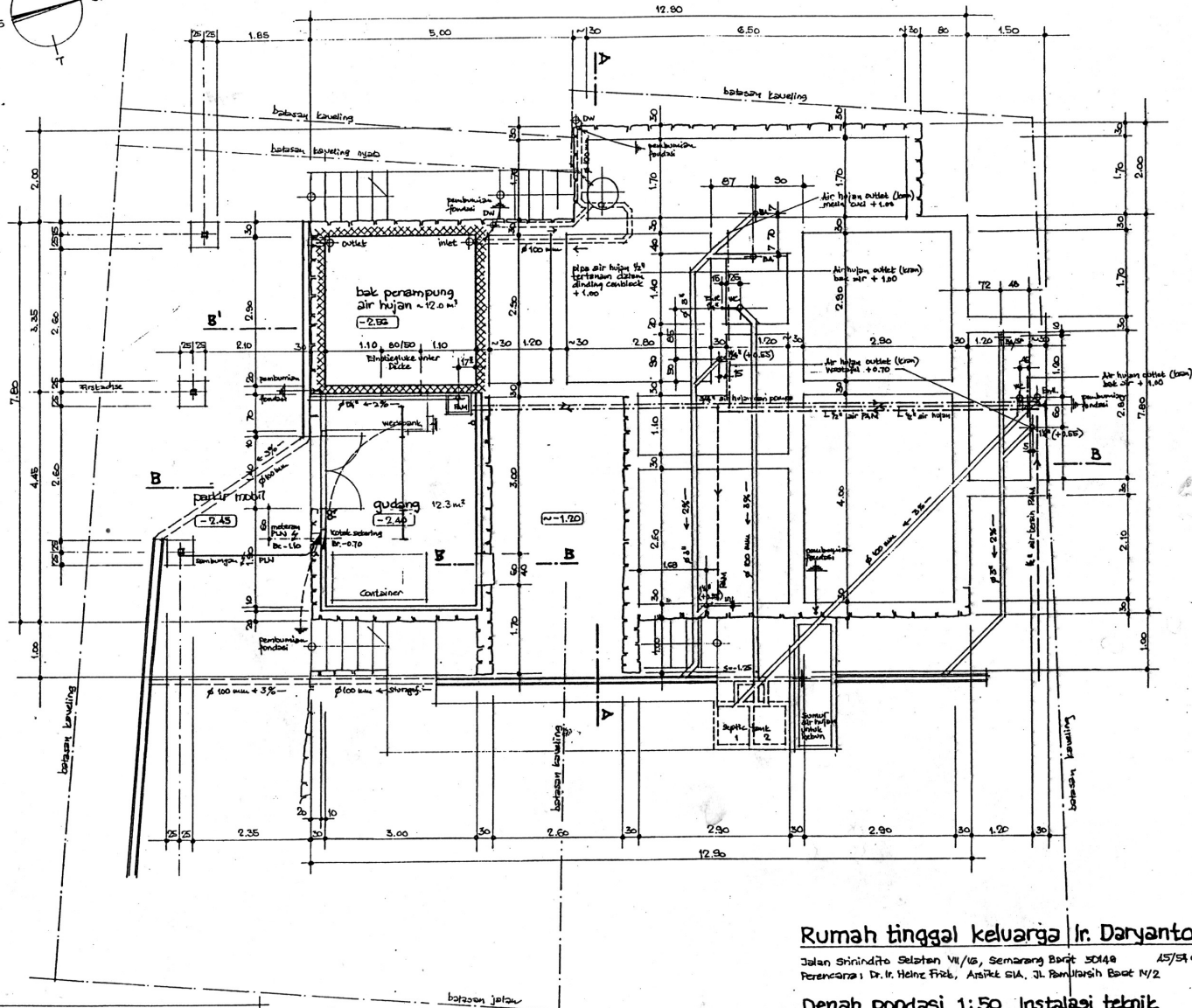
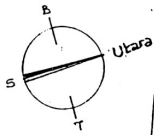

Rumah tinggal keluarga Ir. Daryanto

Jalan Srinandito Selatan VII/48, Semarang Barat 50148 45/54 on
Perencana: Dr. Ir. Helmi Frits, Aisrik SIA, Jl. Ramularsih Barat IV/2

Denah pondasi 1:50 Instalasi teknik

00.1.03/5.0.00

